

THIS DRAWING IS UNPUBLISHED. RELEASED FOR PUBLICATION
 © COPYRIGHT BY TYCO ELECTRONICS CORPORATION. ALL RIGHTS RESERVED.

LOC		DIST		REVISIONS			
AJ	00	P	LTR	DESCRIPTION	DATE	DWN	APVD
		R1		REV PER ECO 06-029805	2/6/2007	DW	JL

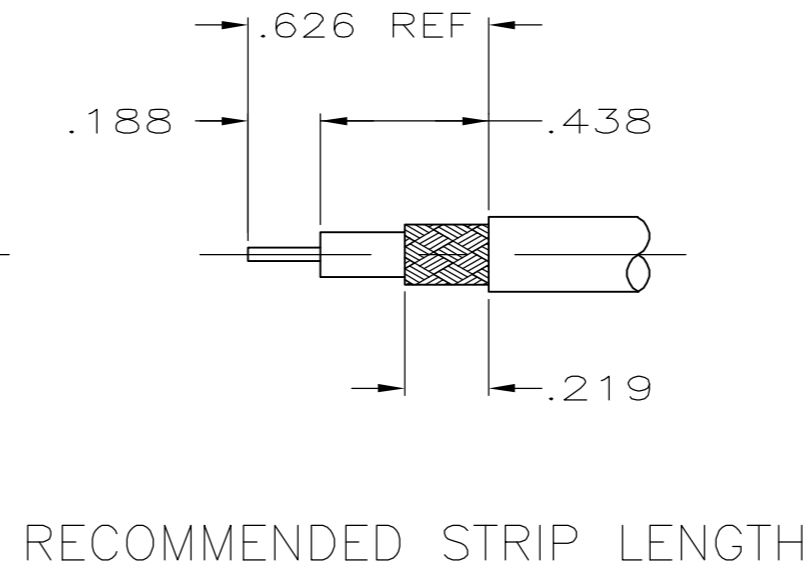
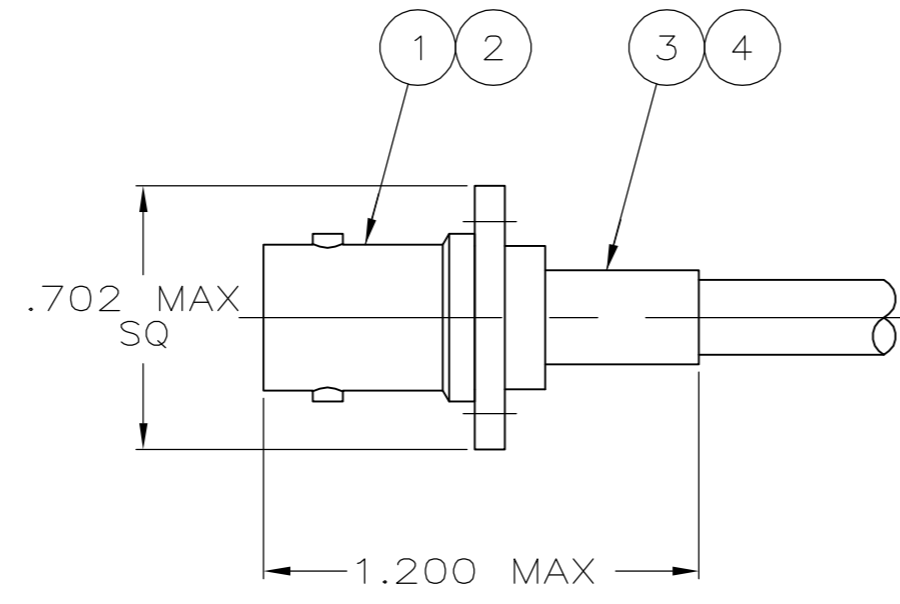
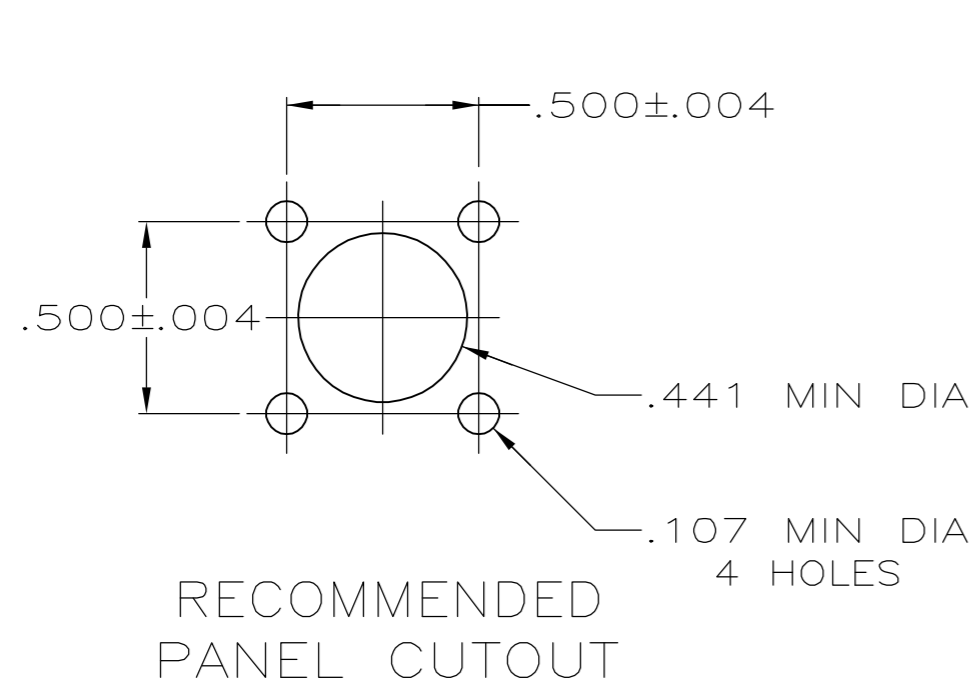

△ SEE I.S. 1914-4

	OBSOLETE	RG-58/U,58A/U,58B/U & 58C/U	69478-1	.391 OZ	—————	9-50427-1	1-331369-6	1-331791-2	9-225397-0
	OBSOLETE	RD-188/U, 316/U	220009-1	-	21427-2	9-329049-0	1-331368-2	1-331791-4	1-225397-4
SUPERSEDED BY	225397-7	RG-174/U & 188/U	220009-1	-	21427-2	9-328666-0	1-331368-2	1-331791-5	1-225397-3
		AMPHENOL 21-597	69477-2	.023565 LB	—————	9-329461-0	1-331368-2	1-331791-4	1-225397-0
	OBSOLETE	RG-179/U & 187/U	220009-1	.023601 LB	21427-2	9-328666-0	1-331368-4	1-331791-4	225397-8
		RG0174/U, 188/U, 316/U	220009-1	.023583 LB	21427-2	9-328666-0	1-331368-2	1-331791-4	225397-7
	OBSOLETE	RG-55/U,55A/U,55B/U & 223/U	69478-1	.023869 LB	—————	9-329099-0	1-331369-6	1-331791-2	225397-3
		RG-59B/U & 62B/U	69477-1	.024369 LB	—————	9-50428-0	2-331368-3	1-331791-3	225397-2
		RG-58/U,58A/U,58B/U & 58C/U	69478-1	.391 OZ	—————	9-50427-1	1-331369-6	1-331791-2	225397-1
	FOR USE WITH CABLE:	CRIMPING TOOL	WEIGHT	④ BUSHING QTY=1	③ FERRULE QTY=1	② CONTACT QTY=1	① JACK ASSY, PANEL QTY=1	PART NO	

THIS DRAWING IS A CONTROLLED DOCUMENT.

DWN	J. L. GROFT	4-25-90
CHK	R. E. RUTH	5/25/90
APVD	-	-
PRODUCT SPEC	-	
APPLICATION SPEC	-	
WEIGHT	-	-
CUSTOMER DRAWING	-	

TOLERANCES UNLESS OTHERWISE SPECIFIED:
 0 PLC ± -
 1 PLC ± -
 2 PLC ± -
 3 PLC ± .016
 4 PLC ± -
 ANGLES ± -
 FINISH -

tyco Electronics Tyco Electronics Corporation
 Harrisburg, PA 17105-3608

JACK, PANEL, DUAL CRIMP, BNC

SIZE	A2	CAGE CODE	00779	DRAWING NO	C=225397	RESTRICTED TO	-
SCALE	1:1	SHEET	1 of 1	REV	R1		

225397